

SAV 243.01

TRAJNI VPENJALNI MAGNETI

Z drobno delitvijo polov P = 1,9 mm



APLIKACIJA

Primerno za vpenjanje tankih, majhnih, srednjih in velikih obdelovancev.

OBLIKA

Neprekinjen prečni naklon polov, enakomerna zadrževalna sila po celotni širini. Pregrade iz medenine 0,5 mm / jekla 1,4 mm.

Na voljo s prilagoditvijo za sistem držanja obdelovanja z ničelno točko.

TEHNIČNI PODATKI

- Nazivna zadrževalna sila: 80N/cm² (140 x 70)
90 N/cm²
(od 175 x 100)
- Višina magnetnega polja: 6 mm
- Obrabni sloj polovne plošče: 8 mm

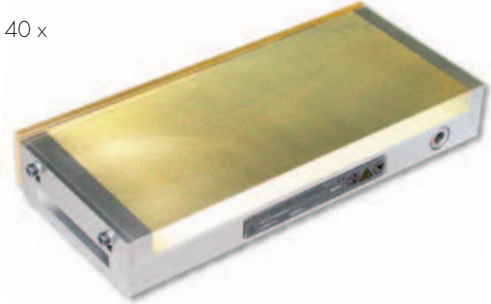

mm					kg	mm					kg
A	B	C ^{+0.5} / ₋₂	D	Weight	A	B	C ^{+0.5} / ₋₂	D	Weight		
140*	70	49	103	3.7	450	150	51	417	30.0		
175	100	49	147	7.0	300	200	51	267	26.2		
200	100	49	177	8.1	400	200	51	373	35.0		
255	130	49	223	14.5	500	200	51	466	43.7		
150	150	51	118	9.8	600	200	51	566	52.4		
250	150	51	223	16.4	500	250	56	464	58.5		
300	150	51	267	19.7	500	300	56	462	70.2		
350	150	51	316	23.0	600	300	56	557	84.2		

* Control on face side with pull bar

ORDERING EXAMPLE

Designation SAV no. - A x B
Permanent magnetic chuck SAV 243.01 - 500 x 200

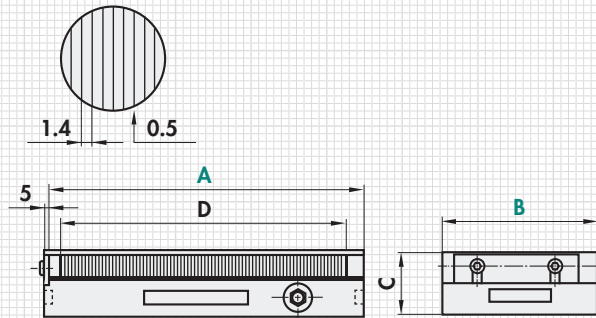

Design with flushing holes for EDM available.